

WASHER

Repair Parts List

MODEL NUMBER

MAH7550AGW

When requesting service or ordering parts, always provide the following information:

- Product Type
- Part Number
- Model Number
- Part Description

MAYTAG®

©2005 Maytag Services

Section: CONTROL PANEL & TOP

Model: MAH7550AGW

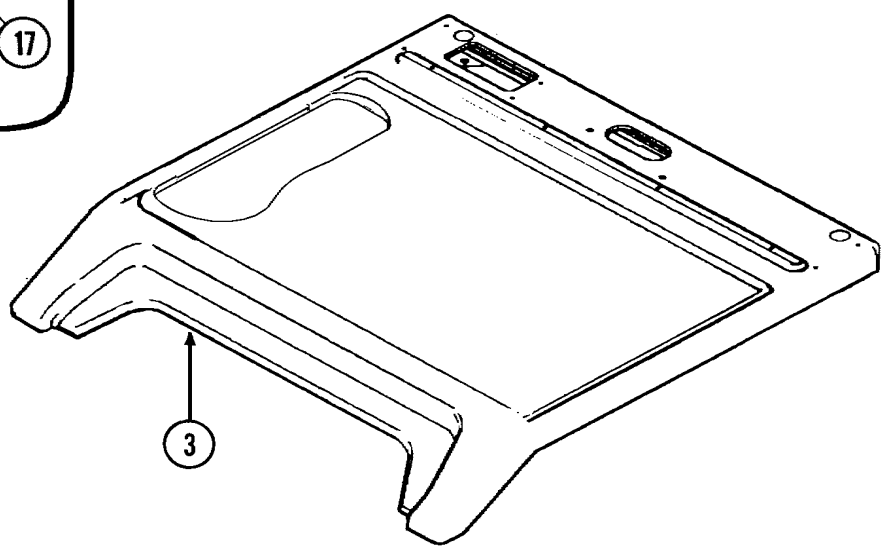
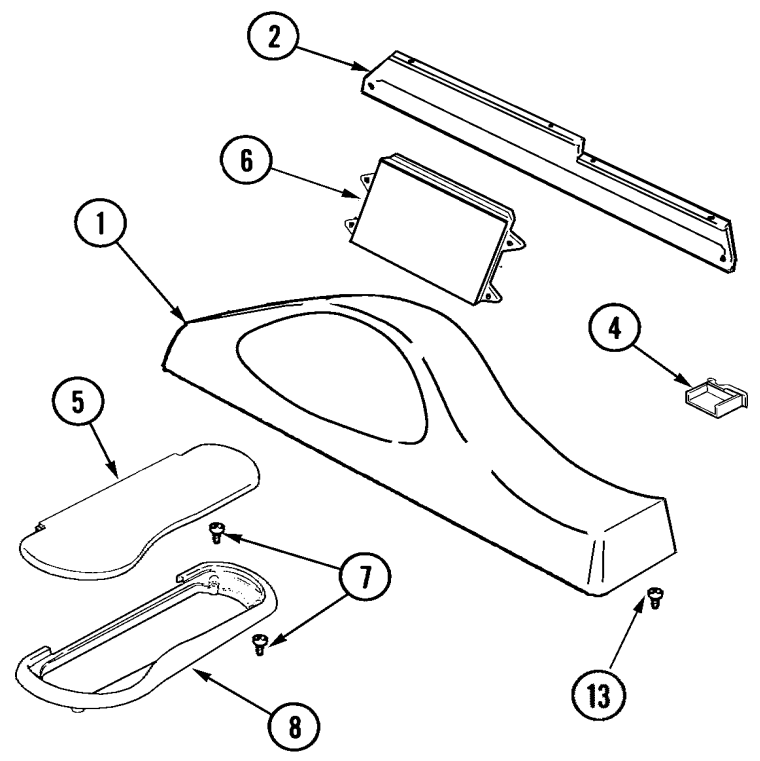
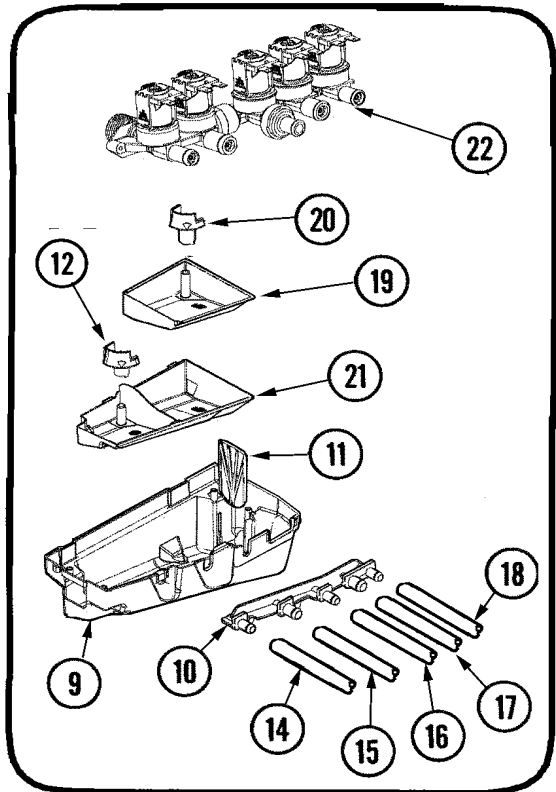

Section: CONTROL PANEL & TOP

No.	Part No.	Description	Series	Qty
1	22004238	LCD MEMBRANE PAC CONSOLE ASSY	34	1
-	22003725	NUT, 8MM	10	1
-	22003050	WIRE, GROUND	10	1
1	22003757	CONSOLE, LCD W/MEMBRANE	10	1
-	22003817	SCREW, SERRATED WASHER HEAD HX	10	1
-	22003817	SCREW, SERRATED WASHER HEAD HX	28	2
-	912365	SCREW	10	3
-	22003858	EMI SUPPRESSION FILTER, 16A	28	1
-	22003909	BRACKET, POWER LINE FILTER	10	1
-	33002501	FILTER, EMI	10	1
2	22003581	BACK, CONSOLE PANEL	10	1
3	22003584	COVER, TOP (WHT-AS PK)	10	1
-	22002925	SCREW Note: SCREW, BRACKET TO TOP COVER	10	2
4	22003276	COVER, CONSOLE PLUG (WHT)	10	1
5	22003760	LID, DISPENSER - EXPORT	10	1
6	22003783	BOARD, MACHINE CONTROL	10	1
-	22002061	SCREW Note: SCREW, CONTROL BOARD	10	4
7	22003681	SCREW, DISPENSER LID Note: SCREW, DISPENSER BEZEL	10	4
8	22003273	BEZEL, DISPENSER (WHT)	10	1
9	22003761	BOTTOM, DISPENSER ASSY.	10	1
10	22003762	DIVERTER, WATER	10	1
11	22003763	GRID, DISPENSER	10	1
12	22003767	SIPHON CAP, DISPENSER MAIN	10	1
13	22003817	SCREW, SERRATED WASHER HEAD HX Note: SCREW, HEX HD TAP/R #8 X 3/8 1-POWER CORD GROUND-TOP COVER 1-MAIN HARNESS & FACIA GROUNDSTO TOP COVER	10	2
-	22003933	CLAMP 332-010-123	10	2
14	22003768	HOSE, INTERNAL SOFTENER FILL	10	1
-	22003933	CLAMP 332-010-123	10	2
15	22003769	HOSE, INTERNAL BLEACH FILL	10	1
16	22003772	HOSE, INTERNAL MAIN WASH FILL	10	1
-	22003933	CLAMP 332-010-123	10	2
-	22003933	CLAMP 332-010-123	10	2
17	22003771	HOSE, INTERNAL PRE-WASH FILL	10	1
-	22003933	CLAMP 332-010-123	10	2
18	22003770	HOSE, INTERNAL HOT FILL	10	1
19	22003764	CUP, LIQUID DETERGENT	10	1
20	22003765	SIPHON CAP, LIQUID DETERGENT	10	1
21	22003766	DISPENSER CUP, MAIN	10	1
-	22002436	SCREW Note: SCREW, WATER VALVE	10	2
22	22003749	VALVE, WATER	10	1
-	22003817	SCREW, SERRATED WASHER HEAD HX	10	1
-	22003725	NUT, 8MM	10	1
-	22003909	BRACKET, POWER LINE FILTER	10	1
-	22003047	FILTER, POWER LINE	10	1
-	22003050	WIRE, GROUND	10	1
-	22004082	SEAL INSERTION TOOL	10	1

*Color Code (-)=Not Shown #=Series, Serial Prefix or Run No., N=Not Available

Section: CABINET-FRONT

Model: MAH7550AGW

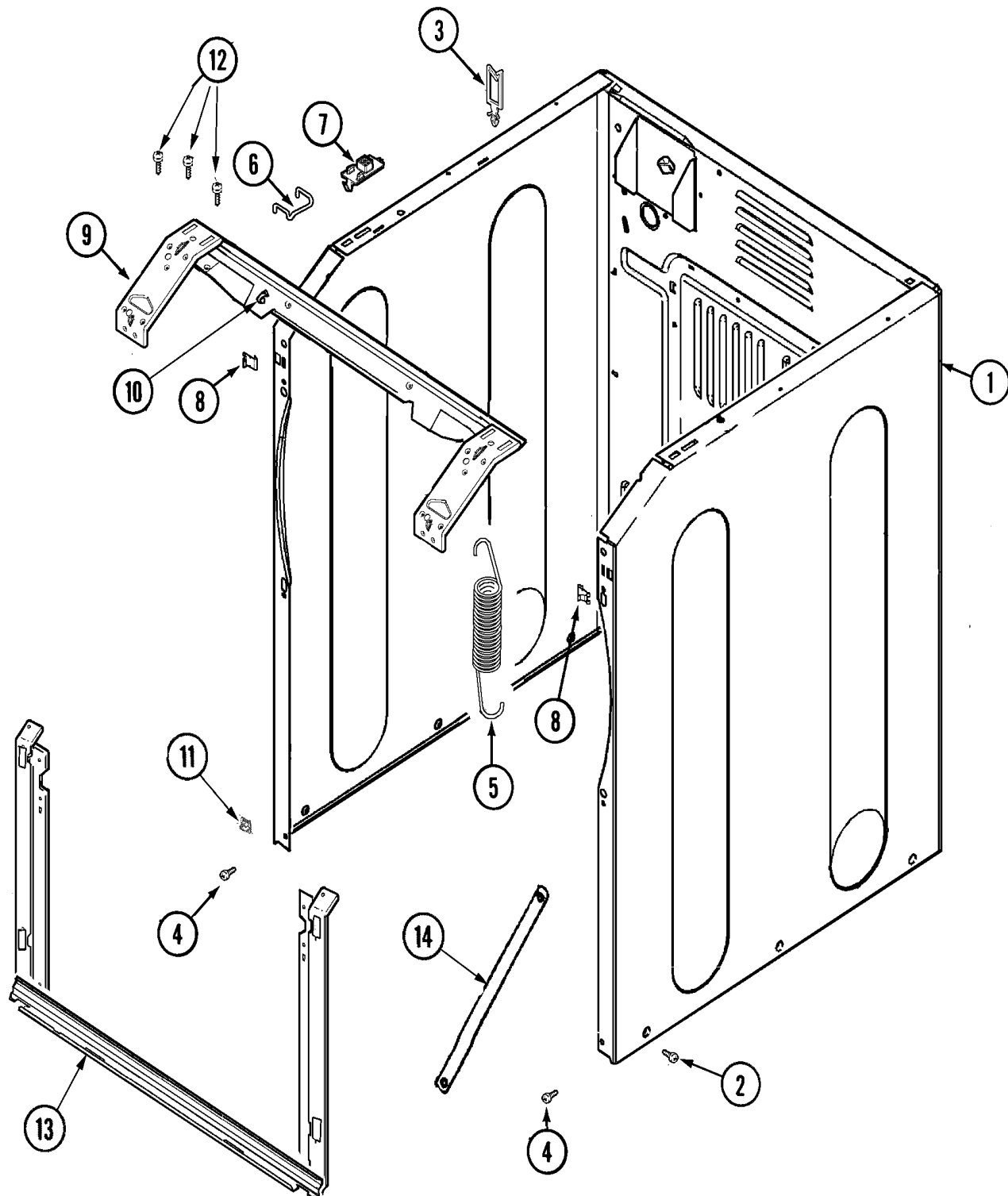

LW12-103

Section: CABINET-FRONT

No.	Part No.	Description	Series	Qty
1	22003639	CABINET ASSY. (WHT AS PK) Note: CABINET ASSY, (WHT, AS PK)	10	1
2	22003409	SCREW----NA Note: SCREW, CABINET (TRUSS)	10	6
3	22003298	RETAINER, WIRE	10	4
-	22001995	SCREW	10	4
4	22001995	SCREW Note: SCREW, FRONT CABINET	10	2
5	22003254	SPRING, CABINET	10	2
6	22002297	SUPPORT, SPRING	10	2
7	22001997	SPACER, TOP COVER	10	2
8	22002049	CLIP Note: CLIP, FRONT PANEL	10	2
9	22003637	BRACE ASSEMBLY, TOP CROSS	10	1
10	22002014	CLIP Note: CLIP, WIRE HARNESS	10	1
11	22002013	STOP, SHIPPING	10	2
12	22001995	SCREW	10	6
-	22001995	SCREW Note: SCREW, SHROUD TO CORNER BRACE	10	4
13	22003652	SHROUD SUPPORT ASSEMBLY	10	1
14	22002259	BRACE, CROSS	10	2
-	22001995	SCREW Note: SCREW, CROSS BRACE	10	4

*Color Code (-)=Not Shown #=Series, Serial Prefix or Run No., N=Not Available

Section: CABINET-REAR

Model: MAH7550AGW

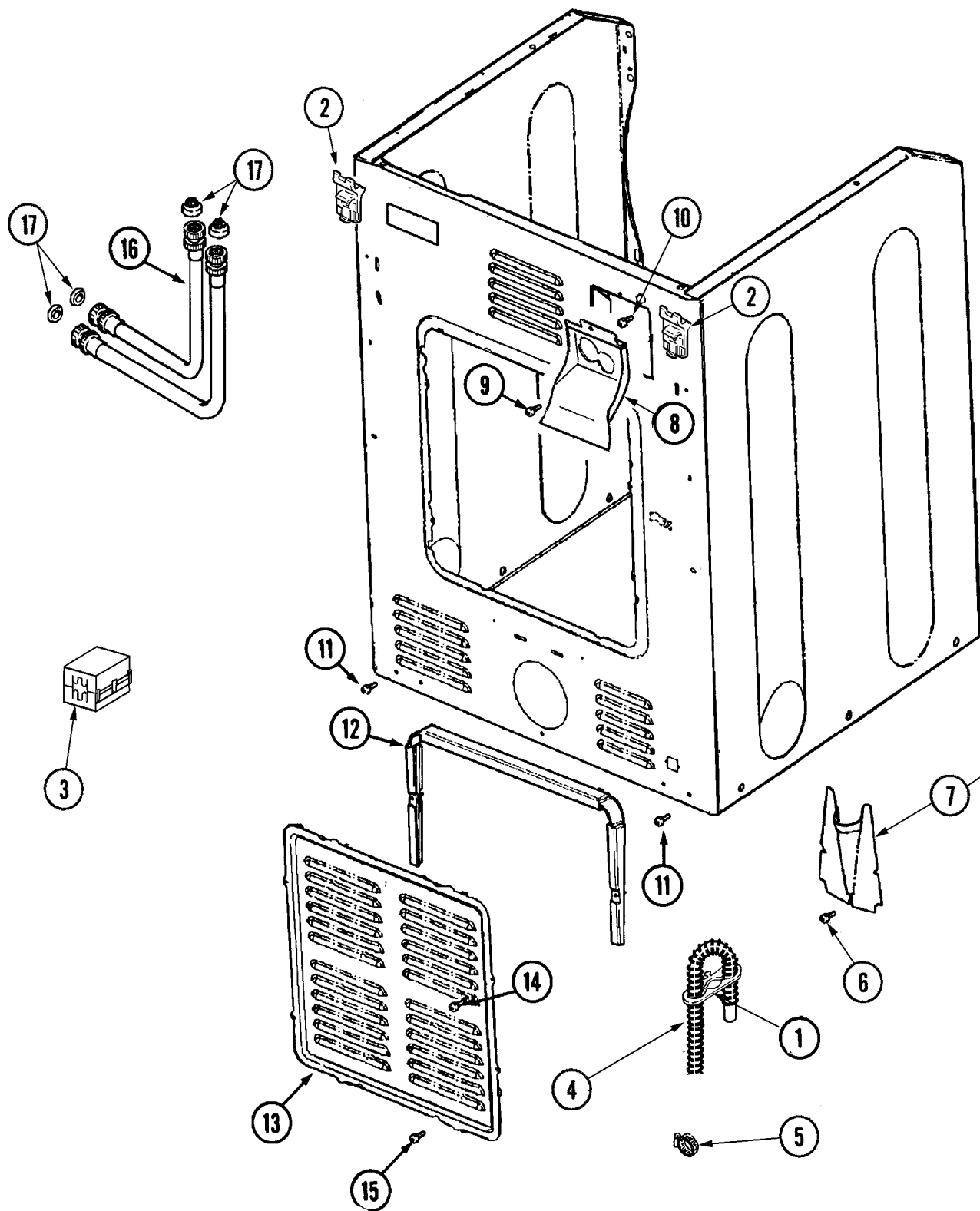

LW12-104

Section: CABINET-REAR

No.	Part No.	Description	Series	Qty
1	22002892	RETAINER, DRAIN HOSE	10	1
-	22001995	SCREW	10	2
2	22003367	HINGE, PLASTIC	10	2
3	33002501	FILTER, EMI	10	1
4	22002932	CLIP, DRAIN HOSE	10	1
-	35-2890	CABLE TIE	10	1
-	12001807	KIT NC, DRAIN HOSE REPLACEMENT	10	1
5	22001984	CLAMP, DRAIN HOSE	10	1
6	22001995	SCREW Note: SCREW, DRAIN HOSE COVER	10	1
7	22002704	COVER, DRAIN HOSE	10	1
8	33002212	BRACKET, WATER VALVE	10	1
-	22002925	SCREW Note: SCREW, VALVE TO BRACKET	10	2
9	22002925	SCREW Note: SCREW, BRACKET TO CABINET	10	2
10 N	33001245	SCREW---NA Note: SCREW, GROUND LUG	10	1
11	22003781	SCREW Note: SCREW, CABINET	10	2
12	22002022	SPACER, ACCESS PANEL	10	1
13	22002092	PANEL, ACCESS	10	1
13	22004355	REAR ACCESS PANEL	11	1
14	22002295	SCREW Note: SCREW, ACCESS PANEL SPACER	10	2
14	22002925	SCREW	11	2
15	22002925	SCREW Note: SCREW, ACCESS PANEL	10	2
-	22003759	HOSE, INLET (COLD)	10	1
16	22003758	HOSE, INLET (HOT)	10	1
-	22003775	STRAINER, NYLON	10	2
-	22003774	WASHER, RUBBER - 2MM	10	2
17	22003776	WASHER, RUBBER - 3MM Note: WASHER, INLET HOSE (3MM)	10	2

*Color Code (-)=Not Shown #=Series, Serial Prefix or Run No., N=Not Available

Section: DOOR & FRONT PANEL

Model: MAH7550AGW

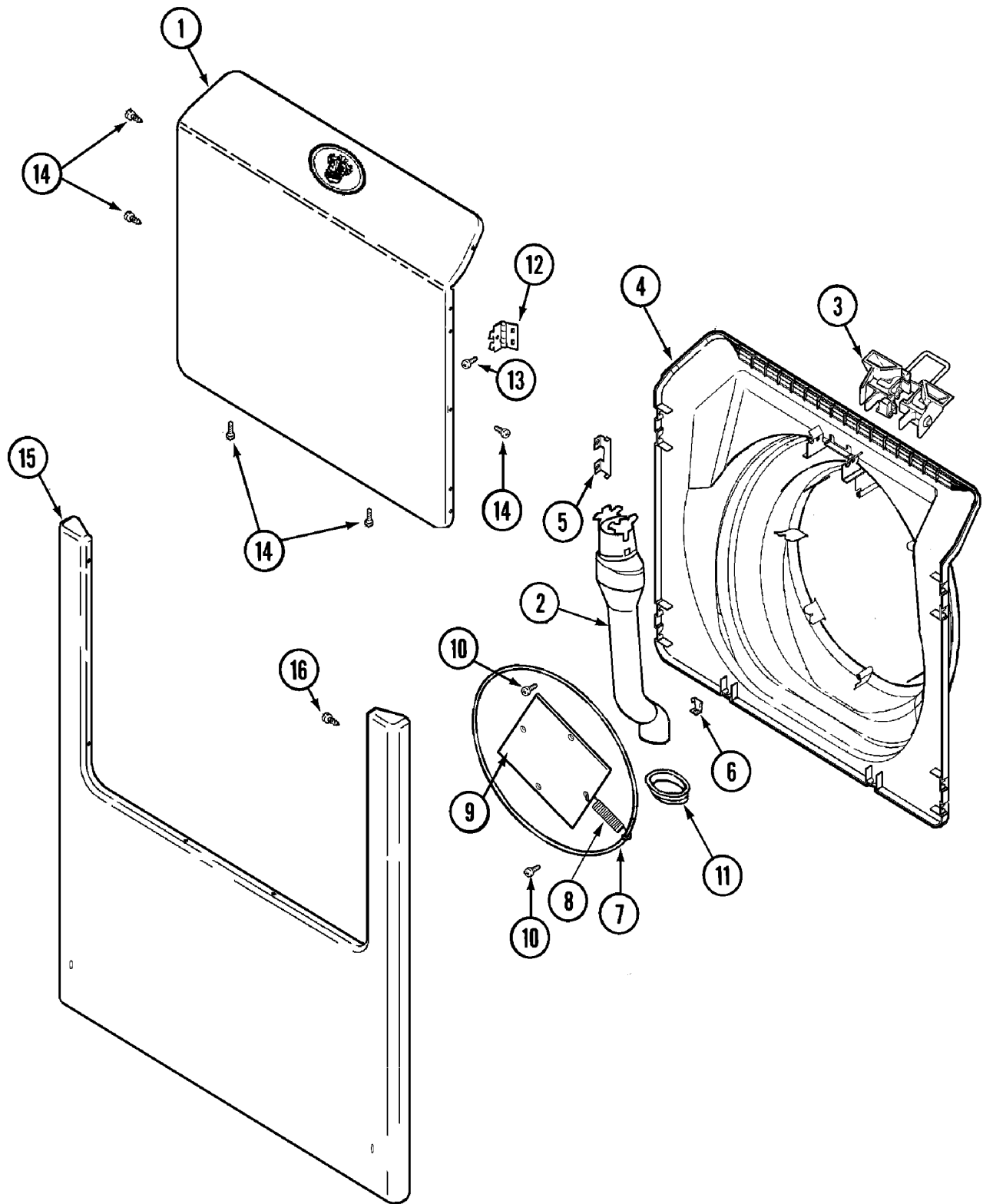

LW18-16

Section: DOOR & FRONT PANEL

No.	Part No.	Description	Series	Qty
1	22003242	DOOR, OUTER W/MEDALLION (WHT)	10	1
2	22003850	VENT TUBE ASSEMBLY	10	1
3	22003269	DOOR, LOCK HOOP ASSEMBLY	10	1
4	22003275	DOOR, INNER (WHT)	10	1
-	22002443	LABEL, SAFETY	10	1
5	22002038	CLIP, DOOR (DOUBLE)	10	4
6	22002039	CLIP, DOOR (SINGLE)	10	2
7	22002104	WIREFRAME Note: REMOVED AT SERIES 40 PER ECN EL43377	10	1
8	22002356	SPRING, PLATE Note: REMOVED AT SERIES 40 PER ECN EL43377	10	4
9	22002094	PLATE Note: REMOVED AT SERIES 40 PER ECN EL43377	10	1
10	22002007	SCREW Note: REMOVED AT SERIES 40 PER ECN EL43377	10	2
11	22003075	GROMMET, VENT TUBE	10	1
12	22003936	WASHER (1 1/4")	10	2
13	22002062	SCREW Note: SCREW, HINGE	10	4
14	22002063	SCREW #8-18AB WAFER HD	10	1
-	22001995	SCREW Note: SCREW, FRONT PANEL CLIP	10	2
-	22002239	CLIP, LOWER FRONT PANEL	10	2
15	22002241	PANEL, FRONT (WHT)	10	1
16	22002012	SCREW, HINGE Note: SCREW, HINGE	10	4
-	22002244	CLIP, GROUNDING	10	1

*Color Code (-)=Not Shown #=Series, Serial Prefix or Run No., N=Not Available

Section: OUTER TUB

Model: MAH7550AGW

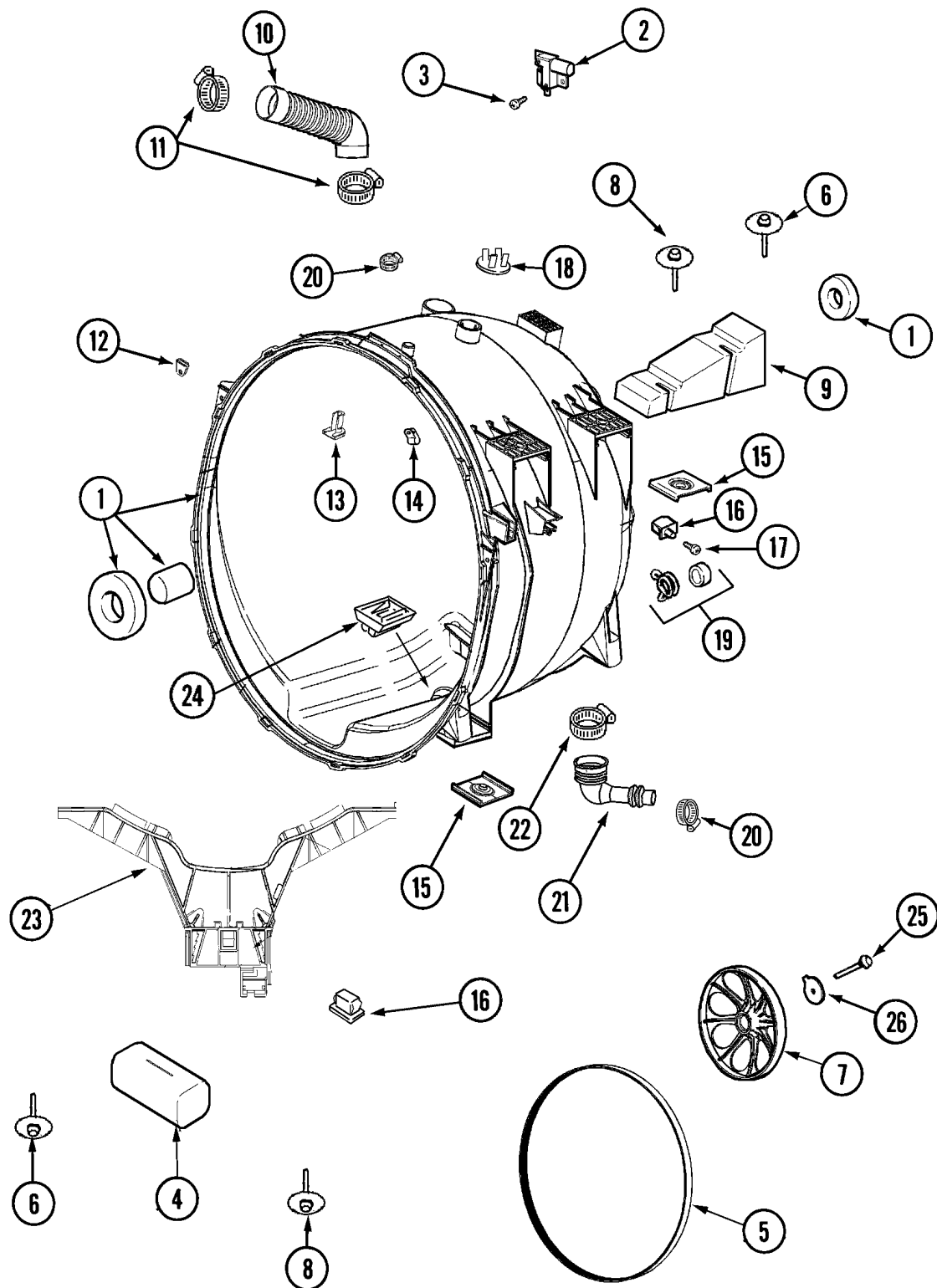

LW13-73

Section: OUTER TUB

No.	Part No.	Description	Series	Qty
1	22003413	OUTER TUB ASSY.(NC AS PACKED) Note: (SPACER & BEARINGS AVAILABLE ONLY WITH OUTER TUB ASSY.)	10	1
1	22004465	OUTER TUB ASSY, AS PACK	38	1
-	22003326	CLIP, HEATER HARNESS TO TUB	10	1
2	22003302	SWITCH, INTERNAL UNBALANCE	10	1
-	22003065	COVER, UNBALANCE SWITCH	10	1
3	22002300	SCREW	10	3
-	22002061	SCREW		1
4	22003827	CUSHION	11	1
5	22002019	SCREW Note: SCREW, WIRE HARNESS CLIP	10	1
5	12001788	KIT, BELT & ISOLATOR	10	1
6	33002973	SCREW, #9-15 X 1.00 HX WS	39	2
6	22003828	PLATED BOLT, DOUBLE SEMS SU	11	2
7	22002014	CLIP Note: CLIP, WIRE HARNESS	10	1
7	22001998	PULLEY, SPINNER	10	1
8	33002973	SCREW, #9-15 X 1.00 HX WS	39	2
8	22003828	PLATED BOLT, DOUBLE SEMS SU	11	2
9	22002102	WEIGHT, COUNTER BALANCE	10	1
10	22002083	HOSE, INJECTOR	10	1
11	22003627	CLAMP, STEPLESS	10	2
12	22002103	CLIP, U	10	2
13	33002222	DEFLECTOR, WATER	10	1
-	22003326	CLIP, HEATER HARNESS TO TUB	10	1
14	22003326	CLIP, HEATER HARNESS TO TUB Note: CLIP, WIRE HARNESS & OUTER TUB	10	3
15	22002065	NUT, COUNTER BALANCE	10	2
16	22002044	SWITCH, TUB DISPLACEMENT	10	2
17	22002061	SCREW	10	1
18	22002797	CLIP, HOSE (SADDLE HORN)	10	1
-	22002061	SCREW Note: SCREW, SADDLE HORN CLIP	10	1
19	22003261	PLUG, OUTER TUB	10	2
20	205161	CLAMP - 15/16" Note: CLAMP - 15/16", TUB TO PUMP	10	1
21	22003262	HOSE, TUB TO PUMP	10	1
22	22002053	CLAMP, SUMP HOSE	10	1
-	22003828	PLATED BOLT, DOUBLE SEMS SU		2
23	22003826	LOWER BRACKET	10	1
23	22004472	BRACKET, LOWER	38	1
-	22003263	SCREW	10	2
24	22003257	CAP, SUMP	10	1
25	22002057	SCREW, SPINNER	10	1
26	22003936	WASHER (1 1/4")	10	1

*Color Code (-)=Not Shown #=Series, Serial Prefix or Run No., N=Not Available

Section: DOOR SHROUD & DOOR LATCH ASSEMBLY

Model: MAH7550AGW

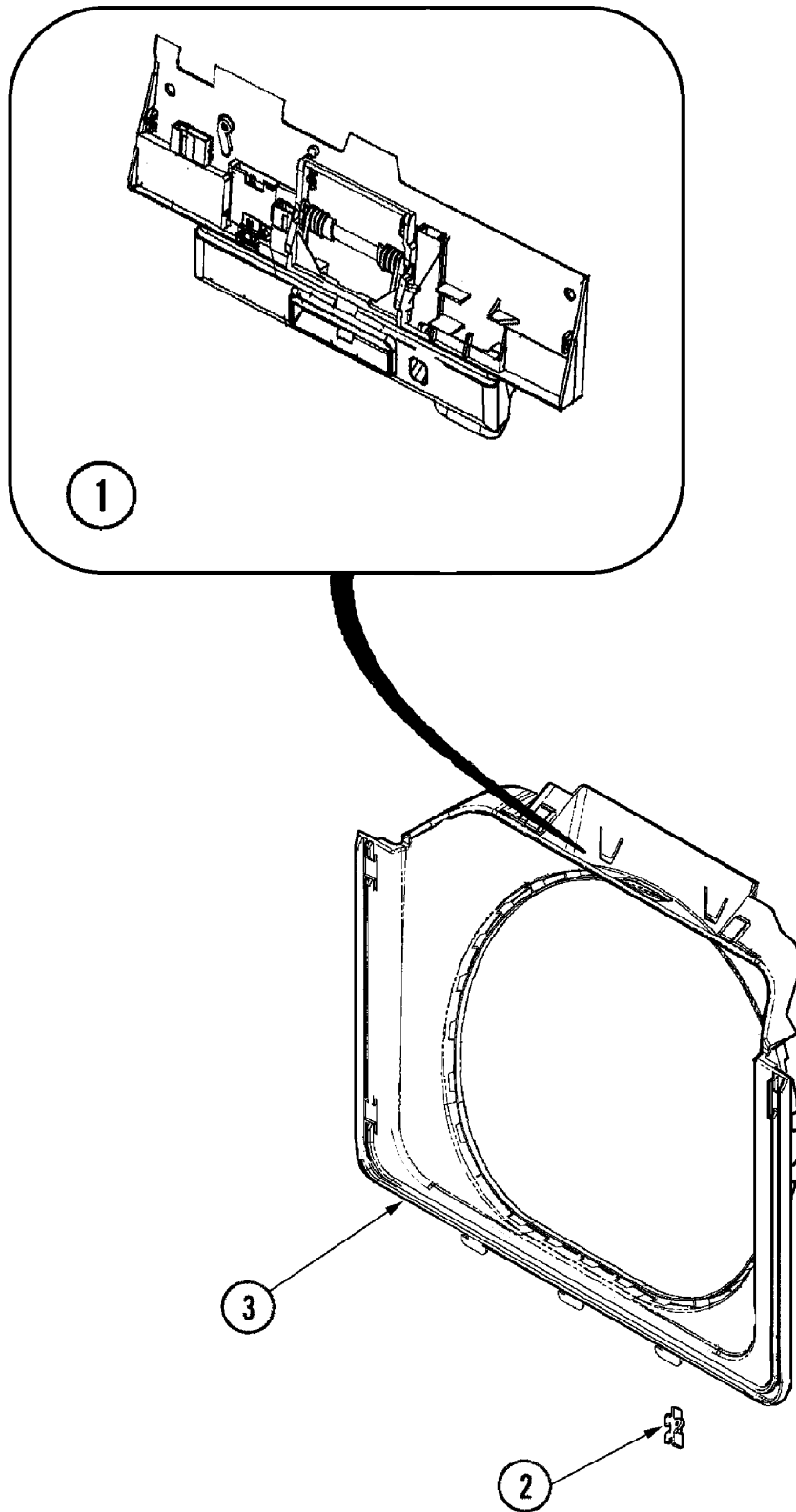

LW20-11

Section: DOOR SHROUD & DOOR LATCH ASSEMBLY

No.	Part No.	Description	Series	Qty
1	22003753	LATCH ASSEMBLY, EXPORT	10	1
-	33001787	SCREW, HINGE	10	2
2	33001764	COVER, HINGE HOLE (WHT)	10	1
3 N	22003516	SHROUD (WHT)----NA	10	1

*Color Code (-)=Not Shown #=Series, Serial Prefix or Run No., N=Not Available

Section: SPINNER ASSEMBLY & OUTER TUB COVER

Model: MAH7550AGW

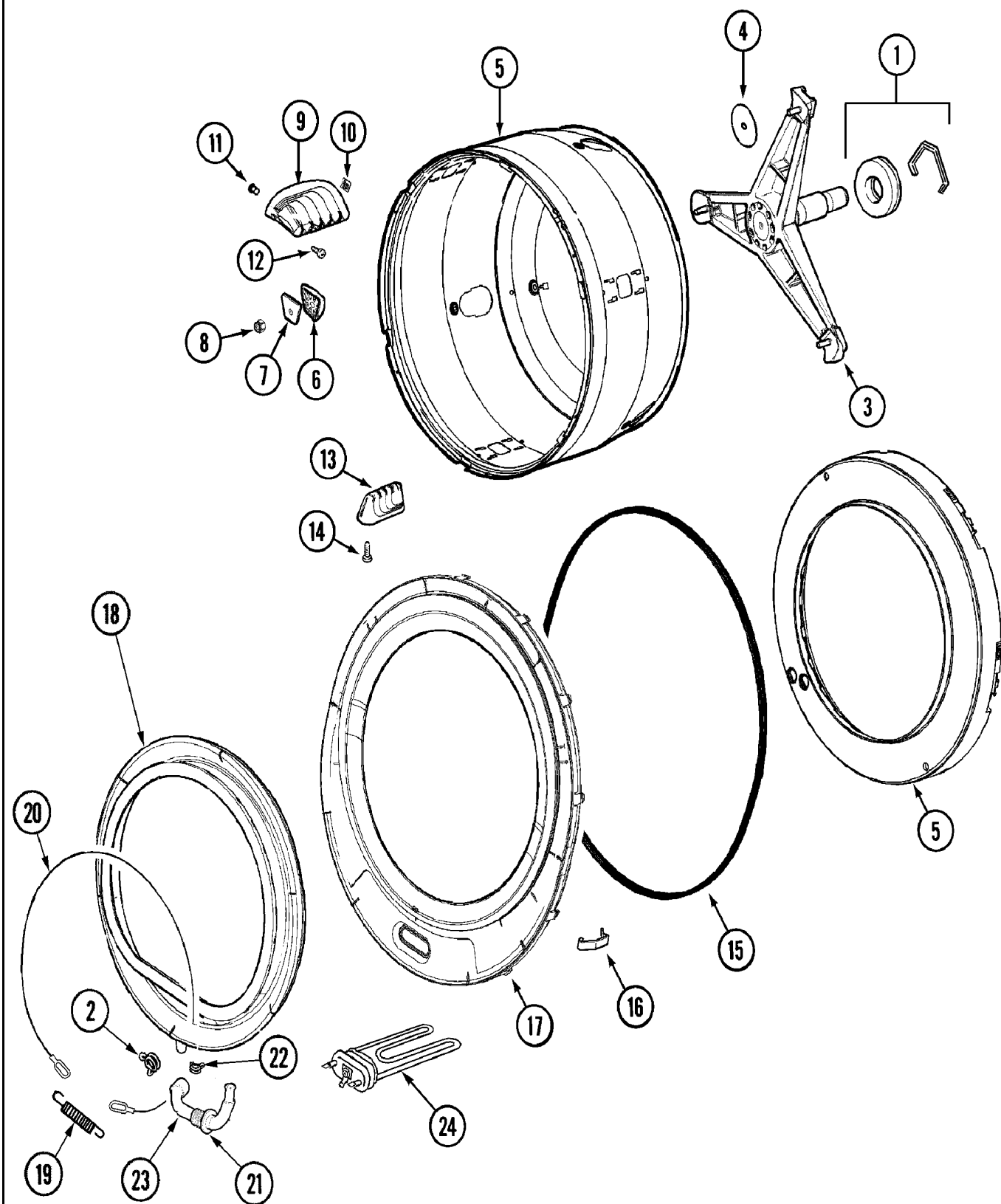

LW20-12

Section: SPINNER ASSEMBLY & OUTER TUB COVER

No.	Part No.	Description	Series	Qty
1	12001478	LIP SEAL SVC ASSY.	10	1
-	12002022	LIP SEAL KIT	22	1
2	22003073	CLAMP, HOSE DOUBLE WIRE	10	1
-	22004108	O RING	22	1
-	22002123	TUBE, MOLYKOTE	10	1
-	22002115	SPINNER ASSY. (W/BALANCE RING)	22	1
3	22004081	SPINNER SUPPORT ASSY AS-PK KIT	10	1
4	22002023	WASHER, PLASTIC	10	3
5	22003670	SPINNER ASSY W' BALANCE RING Note: (BALANCE RING NOT AVAILABLE AS A SEPERATE PART)	10	1
6	22002482	WASHER, PROFILE	10	3
7	22002020	WASHER, SPINNER SUPPORT	10	3
8	22002122	NUT, SPINNER ATTACHMENT	10	3
9	22001985	BAFFLE, DRIP (REAR)	10	3
10	22002009	GROMMET, BAFFLE (REAR)	10	3
11	22001999	GROMMET, BAFFLE (FRT)	10	3
12	22002325	SCREW Note: SCREW, BAFFLE (REAR)	10	6
13	22001986	BAFFLE, DRIP (FRONT)	10	3
14	22002059	SCREW Note: SCREW, BAFFLE (FRONT)	10	6
15	22002077	SEAL, TUB COVER	10	1
16	22002050	CLIP, TUB TO COVER	10	12
-	22003326	CLIP, HEATER HARNESS TO TUB	10	1
17	22003414	TUB COVER ASPK (W/HEATER HOLE)	10	1
-	22004475	TUB COVER ASSEMBLELY W'HEATER	A5	1
18	22003070	DOOR BOOT W/DRAIN (GRAY)	10	1
-	22003081	PLUG	10	1
19	22002099	SPRING, TUB	10	1
20	22002327	BOOT CABLE CLAMP	10	1
21	22003074	GUARD, HOSE	10	1
22	22003072	CLAMP, HOSE DOUBLE WIRE	10	1
23	22003071	DOOR BOOT DRAIN HOSE Note: HOSE, DOOR BOOT DRAIN	10	1
24	22003811	HEATER, 230 V	10	1
-	22003311	THERMISTOR, HEATER	10	1
-	22003779	BRACKET, HEATER	10	1

*Color Code (-)=Not Shown #=Series, Serial Prefix or Run No., N=Not Available

Section: BASE

Model: MAH7550AGW

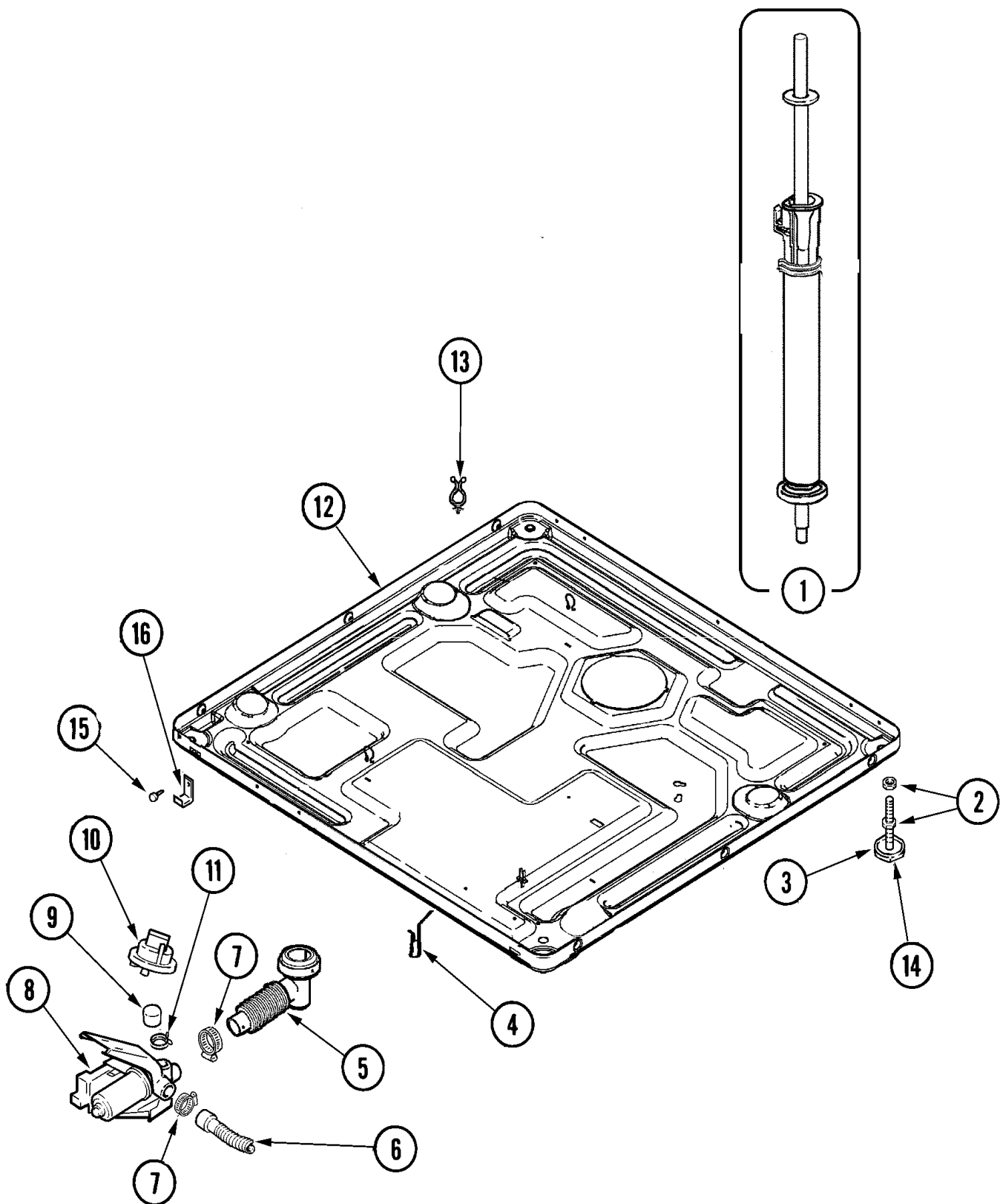

LW10-58

Section: BASE

No.	Part No.	Description	Series	Qty
1	22002316	STRUT, REAR	10	1
2	Y052740	NUT Note: NUT, ADJUSTABLE LEG	10	4
3	305086	ADJUSTABLE LEG & NUT	10	4
4	22002244	CLIP, GROUNDING	10	1
5	22003262	HOSE, TUB TO PUMP	10	1
6	12001807	KIT NC, DRAIN HOSE REPLACEMENT	10	1
7	22003933	CLAMP 332-010-123	10	1
8	25001012	PUMP ISOLATOR BRACKET Note: NOT SHOWN ON GRAPHICS	10	1
8	22003755	PUMP	10	1
9	22003268	CAP, RUBBER	10	1
-	N 22003265	BAG, PLASTIC W/DRAWSTRING	10	1
10	22003754	SWITCH, PRESSURE	10	1
11	22002853	CLAMP, HOSE	10	1
12	22003926	COMMERCIAL BASE WELD ASSY	10	1
13	22003298	RETAINER, WIRE	10	3
14	210684	FOOT, RUBBER	10	4
15	22001995	SCREW	10	2
16	22002239	CLIP, LOWER FRONT PANEL	10	2
-	22003778	TRANSFORMER	10	1
-	22002477	SHIELD, TRANSFORMER	10	1
-	22003756	SCREW, TRANSFORMER TO BASE	10	2

*Color Code (-)=Not Shown #=Series, Serial Prefix or Run No., N=Not Available

Section: WIRING INFORMATION

Model: MAH7550AGW

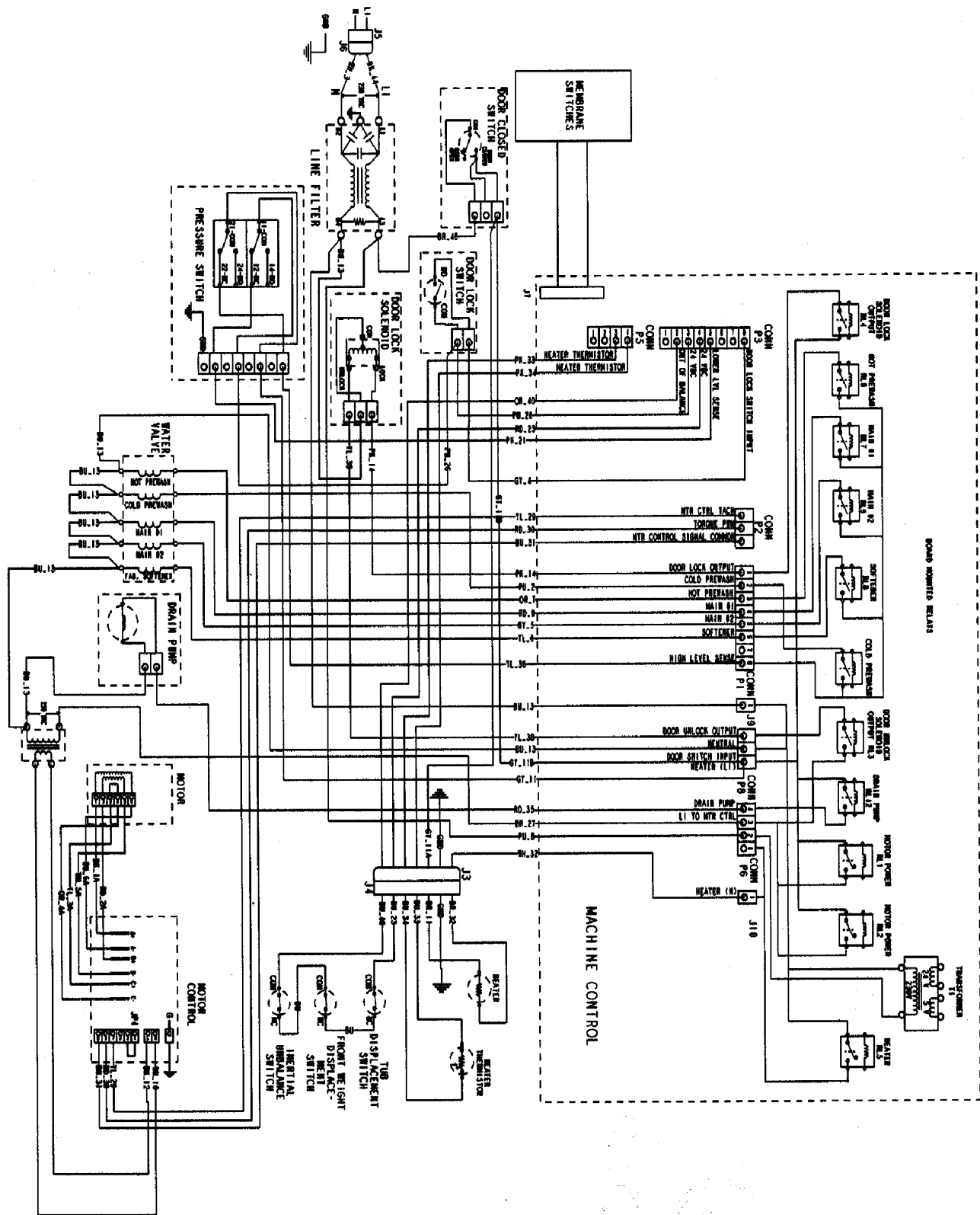

15002912

Section: SUPPLEMENTAL INFORMATION

No.	Part No.	Description	Series	Qty
-	22004102	P CLIPS	28	1
-	22004097	WIRE HARNESS - MAH7550 EXPORT	28	1
-	22002471	WIRE HARNESS, MOTOR CONTROL	10	1
-	22004125	HARNESS, MAH7550 EXPORT	10	1
-	22004126	HARNESS, UNBALANCE EXPORT	10	1
-	22004127	HARNESS UPPER SUB ASSY EXPORT	10	1
-	22003780	MANUAL, USE & CARE	10	1
-	22003932	EXPORT ADAPOR CORD	10	1
- N	22003752	ADAPTER, CORD/TRUE EUROPIAN	10	1
-	22003751	CORD LOCK	10	1
-	22003512	INSULATION, CABINET	10	4
-	22003065	COVER, UNBALANCE SWITCH	10	1
-	22004212	MOTOR HARNESS	10	1
- N	038183	ELECTRICAL TEST CORD	10	1
- N	20001057	MOVER, APPLIANCE	10	1
-	20001069	MULTI-WRENCH, FLAT	10	1
-	20001120	PLIERS, QB PRODUCTS HOSE	10	1
-	22002782	PAD, FOAM (SOUND DAMPENER)	28	1

*Color Code (-)=Not Shown #=Series, Serial Prefix or Run No., N=Not Available





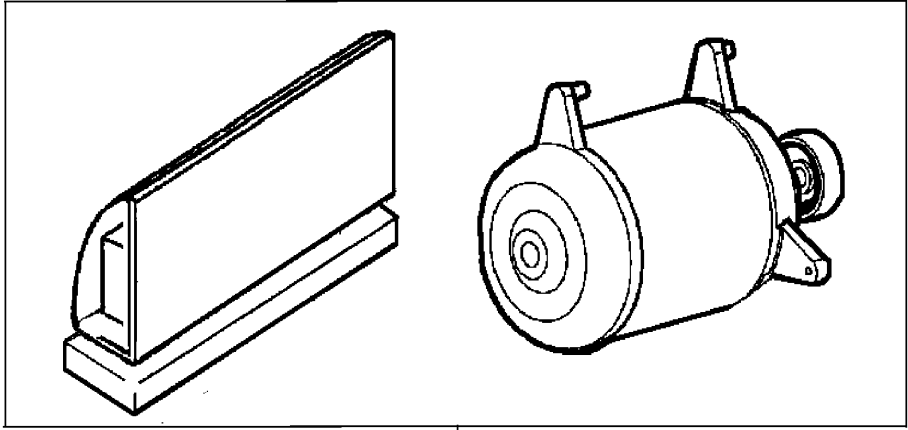



Section: MOTOR & MOTOR CONTROL

Model: MAH7550AGW



1 USE FOR ITEM 2 PRIOR TO SERIES 28

ITEM 1 - KIT CONTAINS:

							
12002040 Motor Isolator	22004046 Motor Control Board	22004047 Motor Harness	22003654 AG Line Filter	22004102 "P" Clips (2)	22002300 Screw - "P" Clip to Motor	22004101 Lower Jumper Wire harness	22004103 Ground Screw

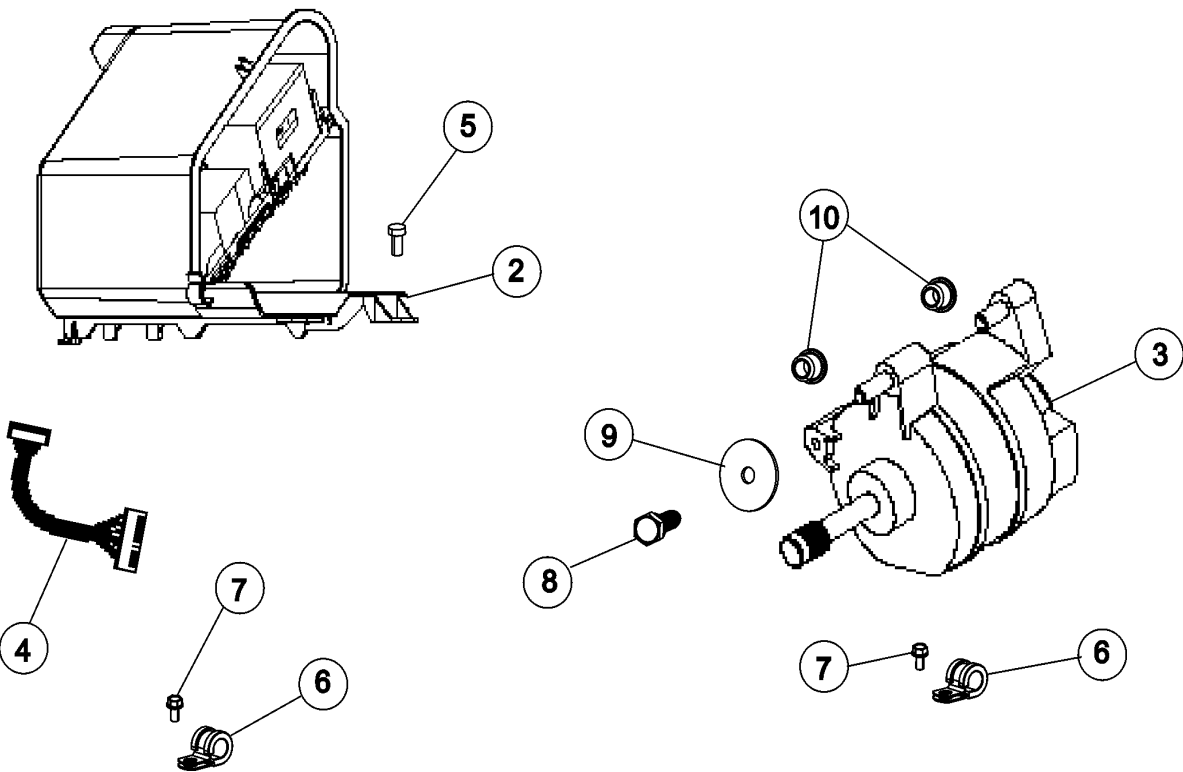

LW14-31

Section: MOTOR & MOTOR CONTROL

No.	Part No.	Description	Series	Qty
1	12002039	NEPTUNE MOTOR CONVERSION KIT	10	1
2	22004046	CONTROL ASSY., MOTOR	62	1
3	22003442	MOTOR, (156 T) 60HZ 120V	10	1
3	22003856	MOTOR, VARIABLE SPEED	27	1
3	22003856	MOTOR, VARIABLE SPEED	62	1
4	22002471	WIRE HARNESS, MOTOR CONTROL	10	1
4	22004047	HARNESS, MOTOR/MOTOR CONTROL	28	1
5	212276	SCREW	10	2
6	22002014	CLIP	10	2
7	22002019	SCREW	10	2
8	N 22002501	VAULT, COIN (WHT) CS	10	1
8	22003858	EMI SUPPRESSION FILTER, 16A	28	1
9	22004101	REPAIR JUMPER HARNESS	10	1
10	22003329	ISOLATOR, MOTOR	10	2
11	22003686	BOLT, MOTOR	10	1
12	22002320	WASHER, STRUT	10	1
13	22002019	SCREW	10	1

*Color Code (-)=Not Shown #=Series, Serial Prefix or Run No., N=Not Available

